

# CiA 447 GW Test TPDO event timing

Testing TPDO 1 and 2 message timing to 5 percent accuracy

File: CiA447\_GW\_PDotime  
Version: 1.00  
Test category: CiA 301 / CiA 447-4 PDO Timing  
Timer resolution: 100 (1ms)  
Global timeout: 60000 (60s)  
Variable used: 2  
Buffer used: 0  
Default bit rate: 125kbps  
DUT ID or range: 1, no range  
Functions off: LSSMaster, PreSeq, PostSeq  
Functions on: SmartID, CiA447ID

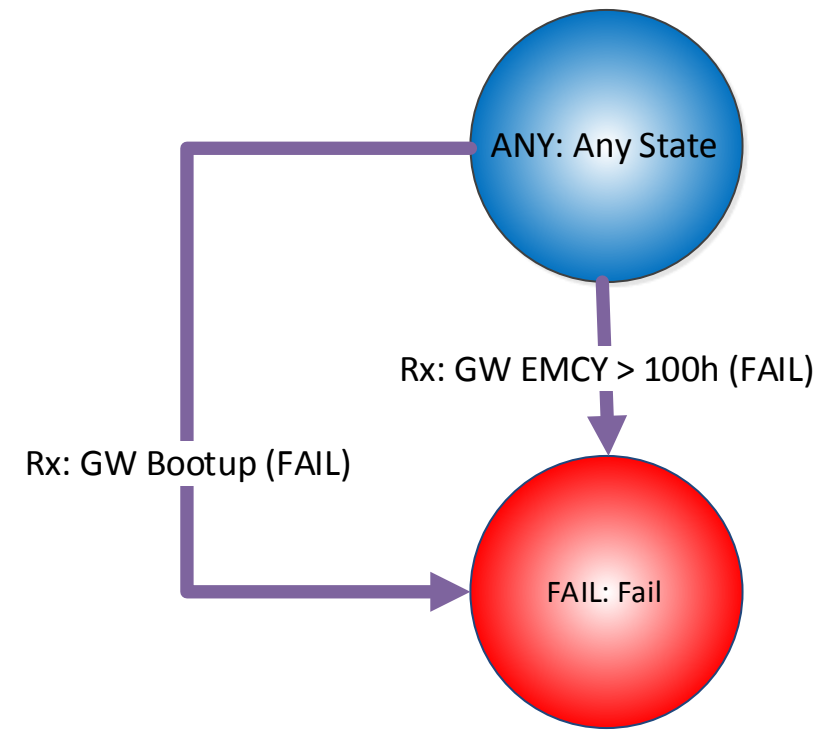
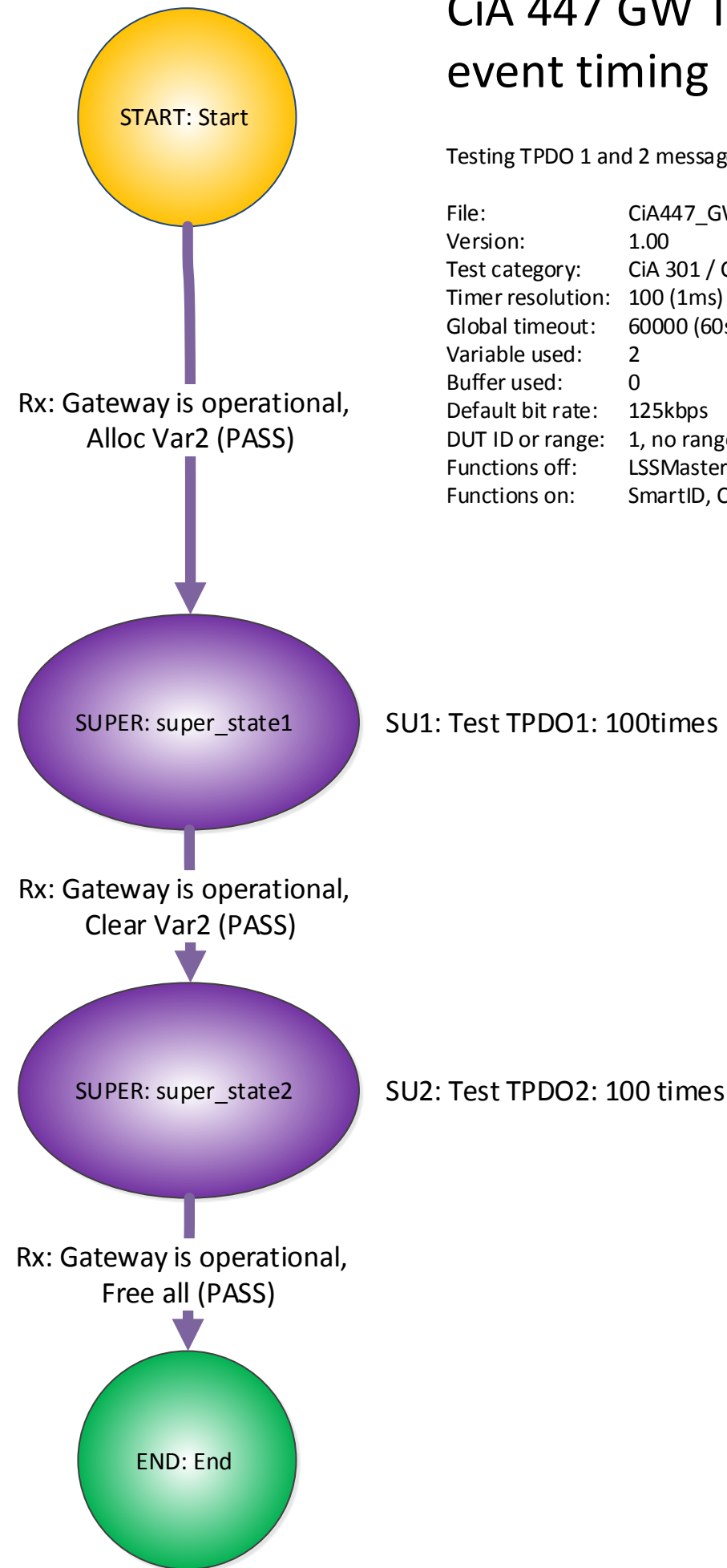

# SU1: Confirm TPDO1 Timing for 100 TPDOs

## Variables:

- 1: PDO Timer
- 2: Loop counter

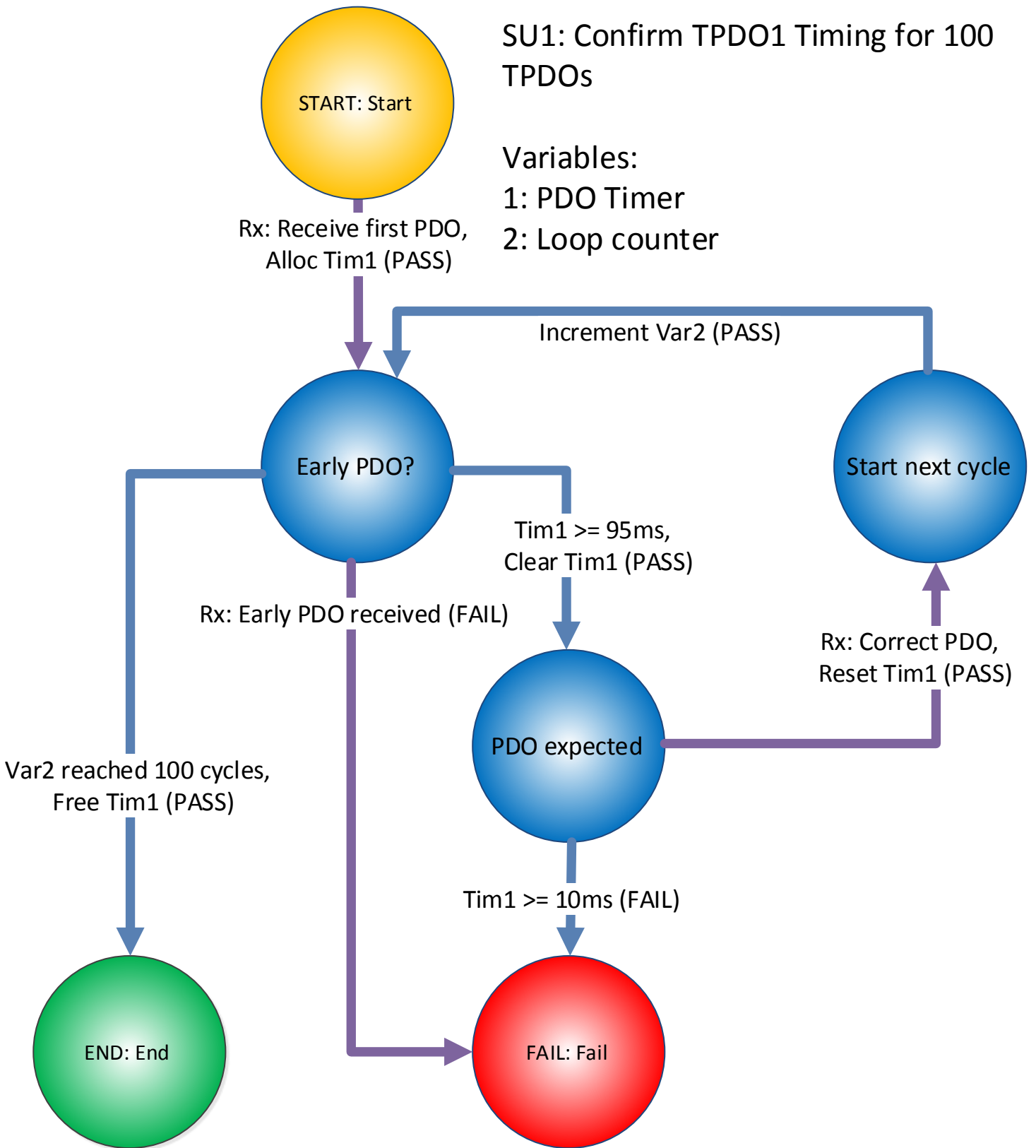

# SU2: Confirm TPDO2 Timing for 100 TPDOs

## Variables:

1: PDO Timer

2: Loop counter

